



STEEL MAKING REFRACTORIES



**TRASTEEL**  
refractory solutions





## INDEX

<b>Trasteel</b>	3
Trasteel <b>map</b>	4
<b>Refractory Solutions</b>	6
Electric Arc Furnace (EAF)	9
Torpedo Car	11
BOF Converter	13
Transfer Ladle	15
Casting Ladle	17
AOD Converter	19
RH Degasser	21
Tundish	23
Isostatics	25
Casting Bricks	27
Special Shapes	29
Sliding Gate System Mechanical	31
Sliding Gate System Refractory	33
<b>Technical Assistance</b>	35





## TRASTEEL

Trasteel Group is a Swiss based Company, established in September 2009, active in production and trading of steel related products such as graphite electrodes, refractories, flat and long products, steel making raw materials such as coking coal, coke and iron ore, non-ferrous metals and solid fuel such as steam coal and pet-coke.

The Group operates as producer in the steel making consumables industry through a partnership put in place directly with one major selected supplier, offering stable and high quality products.

Trasteel idea comes from the entrepreneurship of a group of executives active in the steel industry for more than 25 years. To invest in industrial assets with clear sustainability and competitive long term advantages is the main strategy of the Group. This grants the support of the trading activities, allowing the development of a multitasking and flexible company able to mitigate the high volatility of the markets. Trasteel, in parallel to its trading activities, offers to its Customers a complete range of services, from shipping and logistic to financing, thereby forming an entire business chain with a 360° approach.

Trasteel positioned itself as a multi-geographical player with major focus on China, Middle East, Europe, CIS countries and South America. The Head Office of the Group is based in Lugano, Switzerland, while representative offices are located in South America, UAE, China, Italy, Russia, Congo and South Africa; the rest of the market is entirely covered through the network of agents and Group's representatives.

During the fiscal year of 2018 the Company generated a consolidated turnover in excess of half a billion US dollars and employing almost 100 Professionals.



## HEADQUARTER

- Switzerland
- Luxembourg

## OPERATIONAL OFFICES

- Lugano
- Dubai
- Shanghai
- Bayuquan
- Buenos Aires
- Moscow
- Massa
- Goma

## MARKETS COVERED

- Europe
- Turkey
- Russia
- Ukraine
- Arab Emirates
- Brazil
- Chile
- Colombia
- Argentina
- Perú
- Mexico
- USA
- Indonesia
- Philippines
- Australia
- South Africa
- Congo
- Egypt
- Uzbekistan
- Azerbaijan
- India

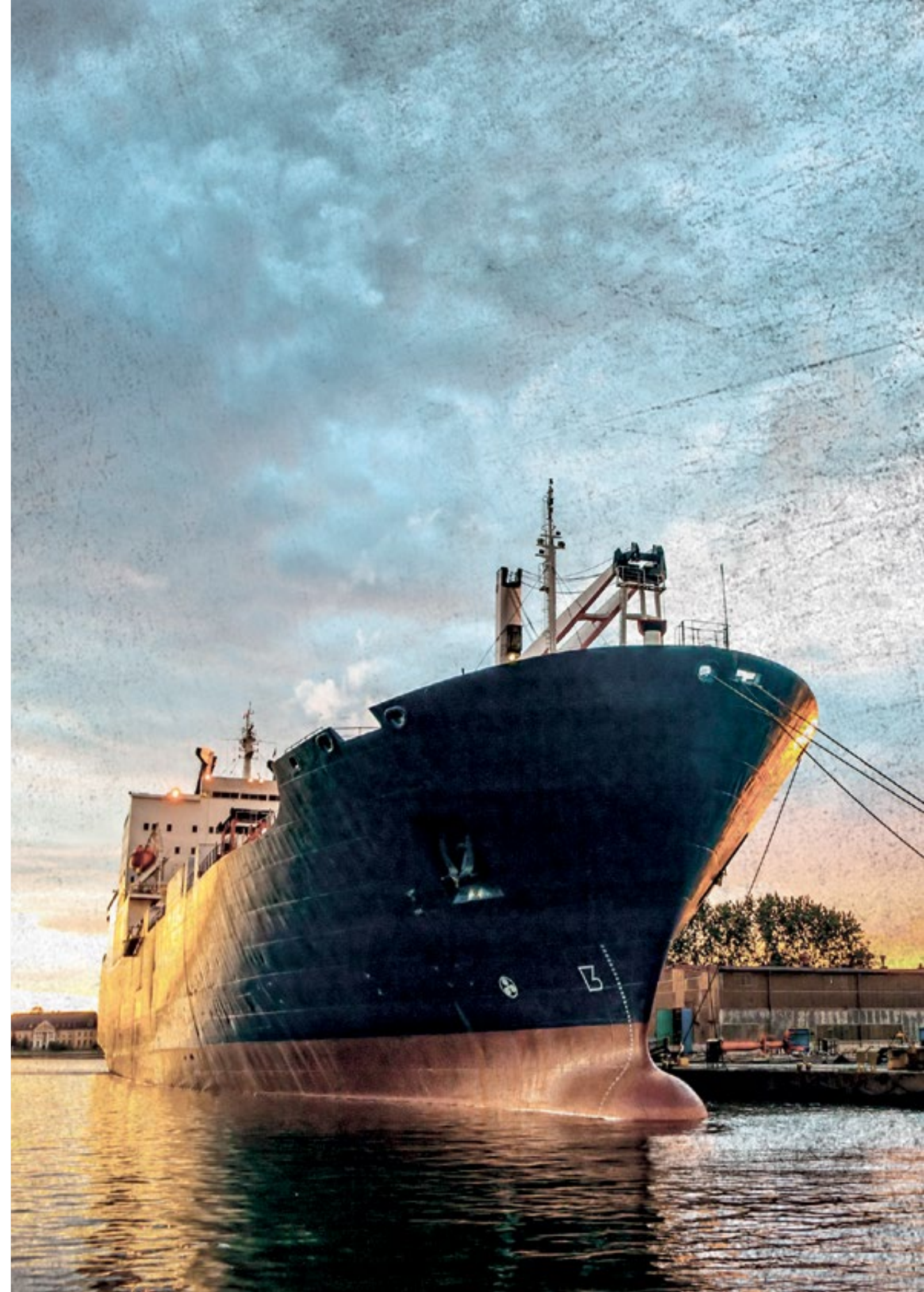



## REFRACTORY SOLUTIONS

Trasteel owns an important stake in one of the **major Chinese Producer of Magnesia-Carbon and Alumina-Magnesia-Carbon refractory bricks**. The established Joint Venture is incorporated under the name of “Yingkou Liangyu - Trasteel Refractory Co. Ltd.”.

Trasteel is acting as the exclusive marketing arm of the Joint Venture on all activities related to overseas marketing, sales, production financing and technology advancement. The Chinese Partner, Liaoning Liangyu Synthetic Refractory Co.,Ltd, has conferred to the Joint Venture their equipment and facilities. The production facilities are located in Dashiqiao City, Liaoning, a province in China close to the highest quality raw material sources for refractory production and major transportation.

The New Joint Venture integrates production and research facilities and is able to produce, with a capacity of about 70'000 MT/year, the following range of products:

- Magnesia Carbon bricks for converters, electric arc furnaces and ladles
- Magnesia Alumina Carbon bricks
- Alumina Silicon Carbide bricks
- Fired Magnesia and fired Magnesia Chrome Bricks
- Fired Magnesia Spinel bricks
- Sliding Gate Plates and Nozzles for Tundish and Ladle flow control
- Various unshaped products for lining installations and maintenance of steel making units.

Our Joint Venture partner owns a magnesite mine with discovered deposits of raw magnesite of **30 million MT** with an annual output of **200'000 MT** assuring to the Joint Venture a reliable and competitive source of fused and sintered Magnesia raw materials.

In order to control its materials and to develop tailor made production based on customers needs, Trasteel established a **technical center** located in Dalian Development Zone, China serving as the company' **Scientific & Research laboratory**. Thanks to the latter, Trasteel is able to analyze all the raw materials used during the production and to test the quality of the final product. The Company implemented this strict and structured approach in order to guarantee the constancy of its production and to make sure that all its guidelines and procedures are respected, so that if necessary immediate actions can be taken during the production.

The Functions of **Trasteel Technical Center** are:

- Quality control system for raw materials and finished products
- Chemical, physical and mineralogical test
- Quality control on all mixes used for the production of finished refractories
- Microstructural investigation for crystal size and component distribution
- Customers support with the development of dedicated solutions and receipts for the most demanding and extreme working conditions

In addition Trasteel has established long-term partnerships with major manufactures of other refractories products:

- Isostatic products for continuous casting machine
- Special shape like purging plugs, EAF plugs, tap hole and well block
- Insulating materials

Having direct control over the Joint venture facilities and thanks to a team of skilled and long-term experienced technicians, Trasteel Refractory Solution can provide its customer with a full range of services including: refractory engineering, training, logistics, installation supervision, after sales assistance and global refractory management service aimed at guaranteeing and even exceeding the performances.





## REFRACTORY MATERIAL FOR EAF

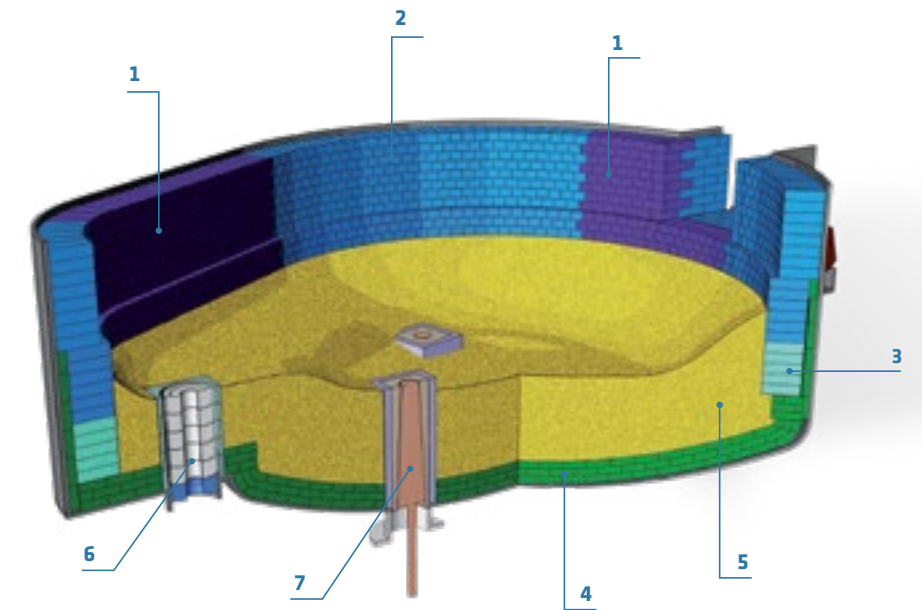

1. Hot spot reinforcement
2. Slag line lining
3. Lower side wall lining
4. Permanent lining
5. Hearth ramming
6. EBT system
7. Purging system

Working lining bricks									
Quality Name	MgO (%)	SiO <sub>2</sub> (%)	CaO (%)	Fe <sub>2</sub> O <sub>3</sub> (%)	Carbon (%)	BD (g/cm <sup>3</sup> )	AP (%)	CCS (Mpa)	Application
EA14L5	98.17	0.39	0.89	0.35	14	2.99	3	45	Hot spot and burners area
E16C5	98.07	0.44	0.93	0.41	16	2.97	3	40	Hot spot and slag zone
E114L2	97.58	0.56	1.16	0.57	14	2.99	3	40	Slag zone
I12C2	97.19	0.65	1.33	0.67	12	3.00	4	42	Slag zone
IP12L2	97.18	0.68	1.39	0.61	12	2.99	4	38	Upper sidewall
O10C2	96.12	0.88	1.74	0.83	10	3.01	4	43	Lower sidewall
I10C2-F3	97.16	1.04	1.12	0.61	10	3.01	4	43	Underbath

Safety lining bricks									
Quality Name	MgO (%)	SiO <sub>2</sub> (%)	CaO (%)	Fe <sub>2</sub> O <sub>3</sub> (%)	Al <sub>2</sub> O <sub>3</sub> (%)	BD (g/cm <sup>3</sup> )	AP (%)	CCS (Mpa)	Application
M93F	93.00	3.40	2.60	1.00	-	2.93	18	60	Safety lining

Unshaped materials									
Quality Name	MgO (%)	SiO <sub>2</sub> (%)	CaO (%)	Fe <sub>2</sub> O <sub>3</sub> (%)	Al <sub>2</sub> O <sub>3</sub> (%)	BD (g/cm <sup>3</sup> )	Grain Size (mm)	CCS (1600°Cx3h) (Mpa)	Application
RAM-M79	79.00	1.30	13.50	5.00	0.50	2.2	0-6	30	Hearth mass
REP-M68HF	65.00	1.02	27.40	2.40	-	2.20	0-6	30	Local hot reparations
RAM-M94U	94.50	0.75	1.20	0.80	0.40	2.72	0-6	20	Joints ramming
GUN-M88V	88.00	6.00	3.00	1.50	1.50	2.20	0-3	-	Gunning for hot and cold reparations
MOR-M93	93.00	2.50	1.80	0.90	0.50	-	0-0.5	-	Mortar for the installation of safety lining bricks

The table does not represent all the available products. More qualities can be produced according to Customer requirements.



## REFRACTORY MATERIAL FOR TORPEDO CAR

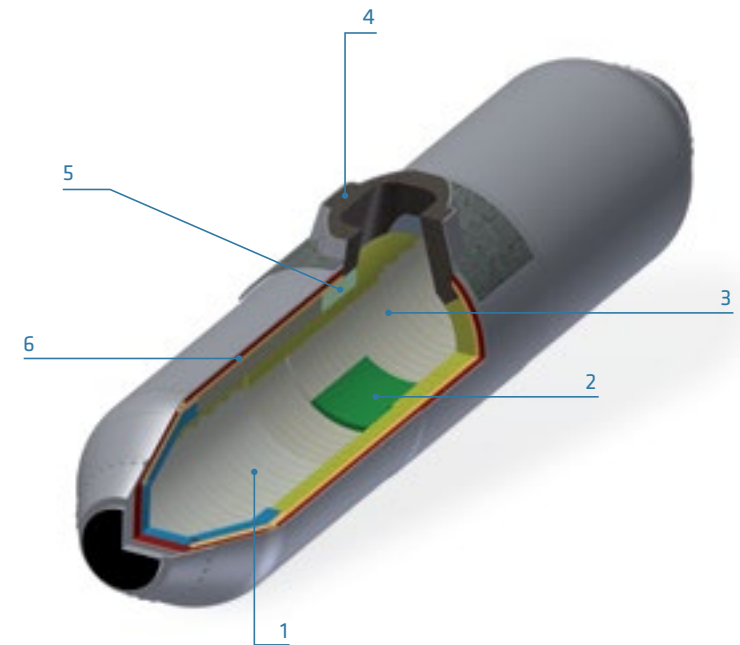

1. Slag line
2. Impact zone
3. Metal zone
4. Mouth
5. Charging hole
6. Safety lining

Working lining bricks								
Quality Name	Al <sub>2</sub> O <sub>3</sub> (%)	SiC (%)	MgO (%)	Carbon (%)	BD (g/cm <sup>3</sup> )	AP (%)	CCS (Mpa)	Application
615ASC	71.00	6.20	-	14.5	3.05	7	50	Slag zone
311ASC	80.20	2.70	2.10	10.8	3.21	6	53.8	Slag zone and metal zone
511ASC	72.10	5.30	-	10.5	2.98	6.9	52.6	Slag zone and metal zone
611ASC	70.50	6.00	-	11	2.93	8	58	Metal zone
1212ASC	65.20	11.75	-	12	2.98	7.6	48.7	Impact zone
213ASC	81.00	2.60	-	13.2	3.12	6.4	45	Charging hole

Safety lining bricks								
Quality Name	Al <sub>2</sub> O <sub>3</sub> (%)	SiO <sub>2</sub> (%)	Fe <sub>2</sub> O <sub>3</sub> (%)	K <sub>2</sub> O+Na <sub>2</sub> O (%)	BD (g/cm <sup>3</sup> )	AP (%)	CCS (Mpa)	Application
S182-TP	-	82.00	0.45	0.48	2.24	13.2	40.3	Safety lining
S182B-TP	15.20	82.00	0.45	0.48	2.22	14.5	32	Safety lining

Unshaped materials								
Quality Name	Al <sub>2</sub> O <sub>3</sub> (%)	SiC (%)	SiO <sub>2</sub> (%)	Grain Size (mm)	BD (g/cm <sup>3</sup> )	MOR (1450°Cx3h) (Mpa)	CCS (1450°Cx3h) (Mpa)	Application
CAST-A68BC	68.12	-	8.80	0-8	2.62	12.6	-	Castable to be used in outside area of charging hole
CAST-A76MB	76.00	-	13.50	0-6	2.76	9.8	-	Castable for charging hole
CAST-A59B-MIX	58.96	-	15.60	0-8	2.36	-	21.8	Coating mix for safety lining
MOR-A60SIC	58.80	34.50	-	0-0.2	-	2	-	Mortar for the installation of safety lining bricks

The table does not represent all the available products. More qualities can be produced according to Customer requirements.



## REFRACTORY MATERIAL FOR BOF CONVERTER



1. Lower cone
2. Purging plugs
3. Bottom
4. Slag line
5. Safety lining
6. Taphole reinforcement
7. Upper cone
8. Mouth
9. Scrap impact area

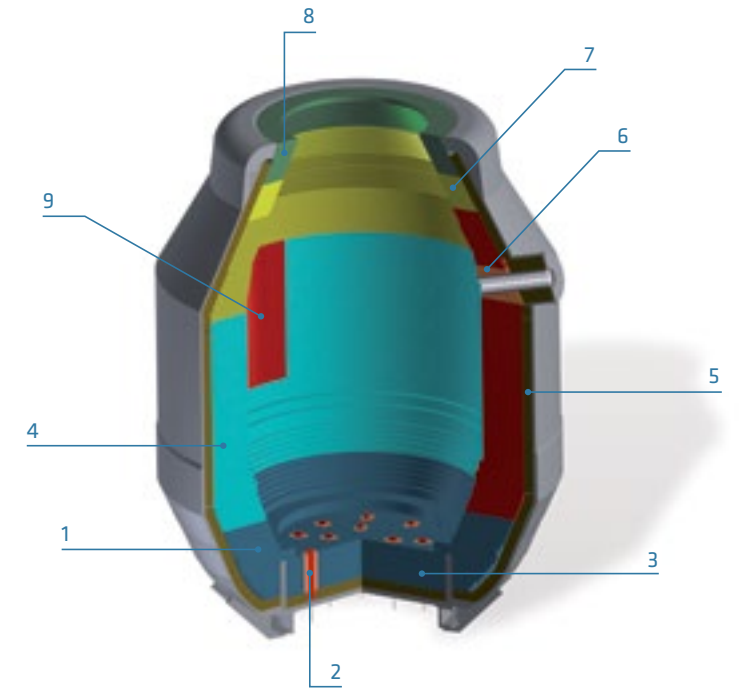

Working lining bricks									
Quality Name	MgO (%)	SiO <sub>2</sub> (%)	CaO (%)	Fe <sub>2</sub> O <sub>3</sub> (%)	Carbon (%)	BD (g/cm <sup>3</sup> )	AP (%)	CCS (Mpa)	Application
A10C6	98.36	0.31	0.88	0.35	10	3.01	2.9	45	Purging plugs reinforcement area
EA14R6	98.15	0.39	0.90	0.39	14	2.99	3	40	Barrel and Trunions area Scrap impact area
E14C6	98.12	0.40	0.91	0.40	14	2.99	3	40	Burrel and Trunions area
E110L3	97.64	0.54	1.18	0.52	10	3.01	4	40	Lower and Upper Cone
I14C6	97.23	0.64	1.30	0.65	14	2.99	3	42	Barrel
IP10L3	97.22	0.66	1.34	0.61	10	3.01	4	40	Mouth
OP10L3	96.66	0.79	1.60	0.68	10	3.00	4	40	Bottom and Joints area

Safety lining bricks									
Quality Name	MgO (%)	SiO <sub>2</sub> (%)	CaO (%)	Fe <sub>2</sub> O <sub>3</sub> (%)	Al <sub>2</sub> O <sub>3</sub> (%)	BD (g/cm <sup>3</sup> )	AP (%)	CCS (Mpa)	Application
M95F	95.00	2.00	1.90	0.80	-	17	60	1650	Safety lining

Unshaped materials									
Quality Name	MgO (%)	SiO <sub>2</sub> (%)	CaO (%)	Fe <sub>2</sub> O <sub>3</sub> (%)	Al <sub>2</sub> O <sub>3</sub> (%)	BD (g/cm <sup>3</sup> )	Grain Size (mm)	CCS (1600°Cx3h) (Mpa)	Application
RAM-M94U	94.50	0.75	1.20	0.80	0.40	2.72	0-6	20	Joints ramming
RAM-M65V	67.00	23.00	4.00	3.00	3.00	1.80	0-2	-	Backfilling safety material
RAM-A75P	-	20.00	-	2.50	75.00	2.00	0-5	-	Protective ramming of a flange
MOR-M93	93.00	2.50	1.80	0.90	0.50	-	0-0.5	-	Mortar for the installation of safety lining bricks

The table does not represent all the available products. More qualities can be produced according to Customer requirements.



## REFRACTORY MATERIAL FOR TRANSFER LADLE

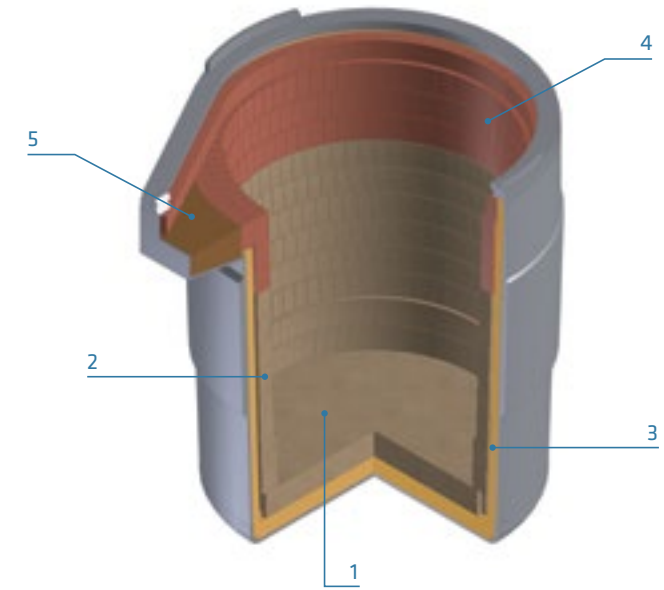

1. Bottom
2. Sidewall
3. Safety lining
4. Slag zone
5. Spout

Working lining bricks									
Quality Name	Al <sub>2</sub> O <sub>3</sub> (%)	MgO (%)	SiC (%)	Fe <sub>2</sub> O <sub>3</sub> (%)	Carbon (%)	BD (g/cm <sup>3</sup> )	AP (%)	CCS (Mpa)	Application
1274C	10.00	74.00	-	-	12	3.06	4	45	Slag zone
1060CS	16.00	60.00	-	-	10	3.06	7	45	Slag zone
712BCS	76.70	11.80	1.00	-	6.9	3.1	6	60	Barrel
810C	78.00	9.92	-	0.70	8	3.2	7	60	Impact area
810BCS	72.80	10.90	-	-	8	3.1	7	60	Bottom and impact area
825B	55.70	25.46	-	1.80	8	3.06	7	50	Barrel and bottom

Safety lining bricks									
Quality Name	Al <sub>2</sub> O <sub>3</sub> (%)	SiO <sub>2</sub> (%)	CaO (%)	Fe <sub>2</sub> O <sub>3</sub> (%)	MgO (%)	BD (g/cm <sup>3</sup> )	AP (%)	CCS (Mpa)	Application
HA80B-L	81.00	-	-	1.80	-	2.92	23	75	Safety lining
HA60A	60.00	38.00	-	0.80	0.1	2.58	17	80	Safety lining
FC48SMLW10	48.31	-	-	1.93	-	1.00	-	5.1	Insulation lining

Unshaped materials									
Quality Name	Al <sub>2</sub> O <sub>3</sub> (%)	SiO <sub>2</sub> (%)	CaO (%)	Fe <sub>2</sub> O <sub>3</sub> (%)	MgO (%)	BD (g/cm <sup>3</sup> )	Grain Size (mm)	CCS (1600°Cx3h) (Mpa)	Application
MOR-A80	80.00	-	-	-	-	-	0-0.2	-	Mortar for the installation of safety lining bricks
CAST-A85CB	85.17	-	1.02	0.80	-	2.90	0-8	91	Castable for refractory lining installation
CAST-A96T	96.25	-	0.80	-	-	2.95	0-5	90	Castable for refractory lining installation
PLAST-A70B	75.14	18.74	-	1.44	-	2.30	0-5	30	Flange ramming

The table does not represent all the available products. More qualities can be produced according to Customer requirements.



# REFRACTORY MATERIAL FOR CASTING LADLE



1. Impact bottom reinforcement
2. Bottom
3. Purging system
4. Sidewall
5. Slag zone
6. Freeboard
7. Safety lining - Slag area
8. Slide gate system
9. Safety lining - Sidewall and bottom area

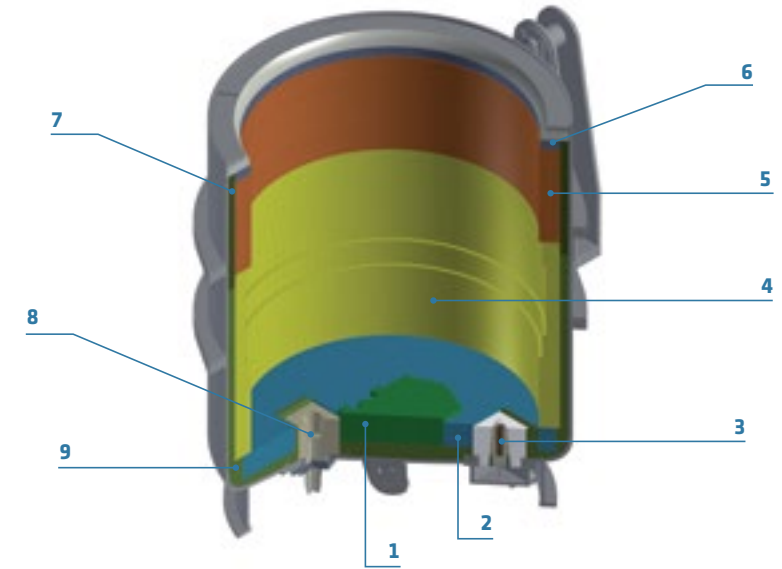

Working lining bricks									
Quality Name	MgO (%)	SiO <sub>2</sub> (%)	CaO (%)	Fe <sub>2</sub> O <sub>3</sub> (%)	Carbon (%)	BD (g/cm <sup>3</sup> )	AP (%)	CCS (Mpa)	Application
EA16L7	98.12	0.38	0.92	0.40	16	2.99	3	40	Slag zone reinforcement
E14C4	98.05	0.44	0.95	0.43	14	3.01	3	40	Bricks for slag zone
EI12L1	97.58	0.56	1.16	0.57	12	3.02	3	40	Bricks for slag zone
I10C1	97.11	0.67	1.37	0.70	10	3.04	4	42	Bricks for sidewall
IP8L1	97.10	0.70	1.43	0.63	8	3.03	5	41	Bricks for sidewall and bottom
OP6L1	96.60	0.80	1.62	0.69	6	3.05	4	43	Bricks for sidewall and bottom
IBC1-F5	97.07	0.90	1.20	0.65	8	3.03	5	44	Bricks for bottom

Safety lining bricks									
Quality Name	MgO (%)	SiO <sub>2</sub> (%)	CaO (%)	Fe <sub>2</sub> O <sub>3</sub> (%)	Al <sub>2</sub> O <sub>3</sub> (%)	BD (g/cm <sup>3</sup> )	AP (%)	CCS (Mpa)	Application
M91F	91.50	4.10	2.50	1.20	-	2.92	19	60	Safety lining - Slag area
HA80B-L	-	-	-	1.80	81.00	2.92	23	75	Safety lining - Sidewall and bottom area
HA60A	0.10	38.00	-	0.80	60	2.58	17	80	Safety lining
FC48SMLW10	-	-	-	1.93	48.31	1.00	-	5.1	Insulation lining

Unshaped materials									
Quality Name	MgO (%)	SiO <sub>2</sub> (%)	CaO (%)	Fe <sub>2</sub> O <sub>3</sub> (%)	Al <sub>2</sub> O <sub>3</sub> (%)	BD (g/cm <sup>3</sup> )	Grain Size (mm)	CCS (1600°Cx3h) (Mpa)	Application
RAM-M94U	94.50	0.75	1.20	0.80	0.40	2.72	0-6	30	Joints ramming
GUN-M88V	88.00	6.00	3.00	1.50	1.50	2.20	0-3	-	Cunning for hot and cold reparations
MOR-M91	87.00	4.50	2.10	5.00	1.50	-	0-0.3	-	Mortar for the installation of safety lining bricks
MOR-A80	-	-	-	-	80.00	-	0-0.2	-	Mortar for the installation of safety lining bricks
CAST-A85CB	-	-	1.02	0.80	85.17	2.90	0-8	91	Castable for refractory lining installation
CAST-A96T	-	-	0.80	-	96.25	2.95	0-5	90	Castable for refractory lining installation
PLAST-A70B	-	18.74	-	1.44	75.14	2.30	0-5	30	Flange ramming

The table does not represent all the available products. More qualities can be produced according to Customer requirements.



## REFRACTORY MATERIAL FOR AOD CONVERTER



1. Bottom
2. Safety lining
3. Tuyere area
4. Lower cone
5. Slag line
6. Upper cone

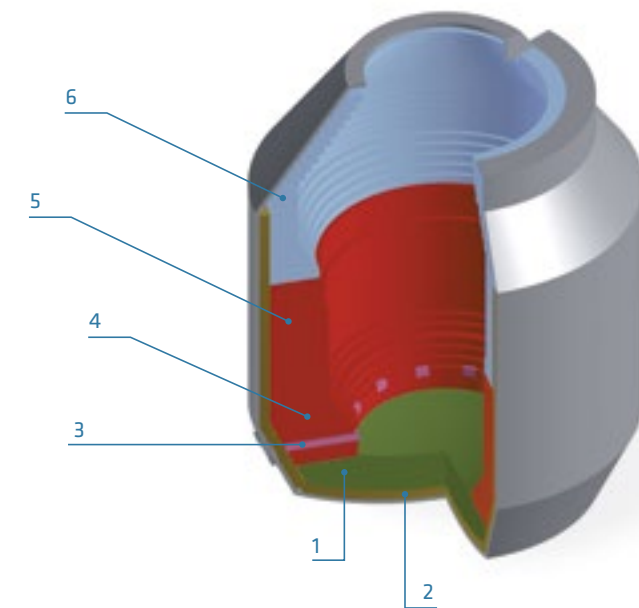

Working lining bricks									
Quality Name	MgO (%)	CaO (%)	SiO <sub>2</sub> (%)	Fe <sub>2</sub> O <sub>3</sub> (%)	Al <sub>2</sub> O <sub>3</sub> (%)	BD (g/cm <sup>3</sup> )	AP (%)	CCS (Mpa)	Application
MDB-20A	75.00	22.00	1.2	1.10	0.5	2.98	15	70	Slag line
MDB-20AF	75.20	20.60	1.10	0.90	0.4	2.93	14.5	80	Slag line
MDB-30AF	63.50	31.10	1.30	1.20	0.45	2.93	14.5	80	Upper and lower cone
MDB-30AF-TR	64.50	31.50	1.10	0.90	0.4	2.93	12.5	90	Trunion
MDB-25AF-TR	72.00	25.00	1.20	0.70	0.5	2.96	14,5	60	Tuyere Area

Safety lining bricks									
Quality Name	MgO (%)	SiO <sub>2</sub> (%)	CaO (%)	Fe <sub>2</sub> O <sub>3</sub> (%)	Cr <sub>2</sub> O <sub>3</sub> (%)	BD (g/cm <sup>3</sup> )	AP (%)	CCS (Mpa)	Application
M93F	93.00	3.40	2.60	1.00	-	2.93	18	60	Safety lining
M95F	95.20	2.00	1.90	0.80	-	2.95	16	70	Safety lining
CR19	58.00	-	1.30	14.00	19	3.15	18	55	Safety lining

Unshaped materials									
Quality Name	MgO (%)	SiO <sub>2</sub> (%)	CaO (%)	Fe <sub>2</sub> O <sub>3</sub> (%)	LOI	BD (g/cm <sup>3</sup> )	Grain Size (mm)	CCS (1600°Cx3h) (Mpa)	Application
MOR-MD35-J	57.00	4.00	35.00	1.30	-	-	0-5	-	Dolomite mortar
RAM-MD65-V	60.00	-	25.00	-	3.50	2.00	0-3	-	Backfilling material
RAM-MD65	65.00	-	20.00	-	3.50	2.00	0-6	-	Ramming material

The table does not represent all the available products. More qualities can be produced according to Customer requirements.



## REFRACTORY MATERIAL FOR RH DEGASSER

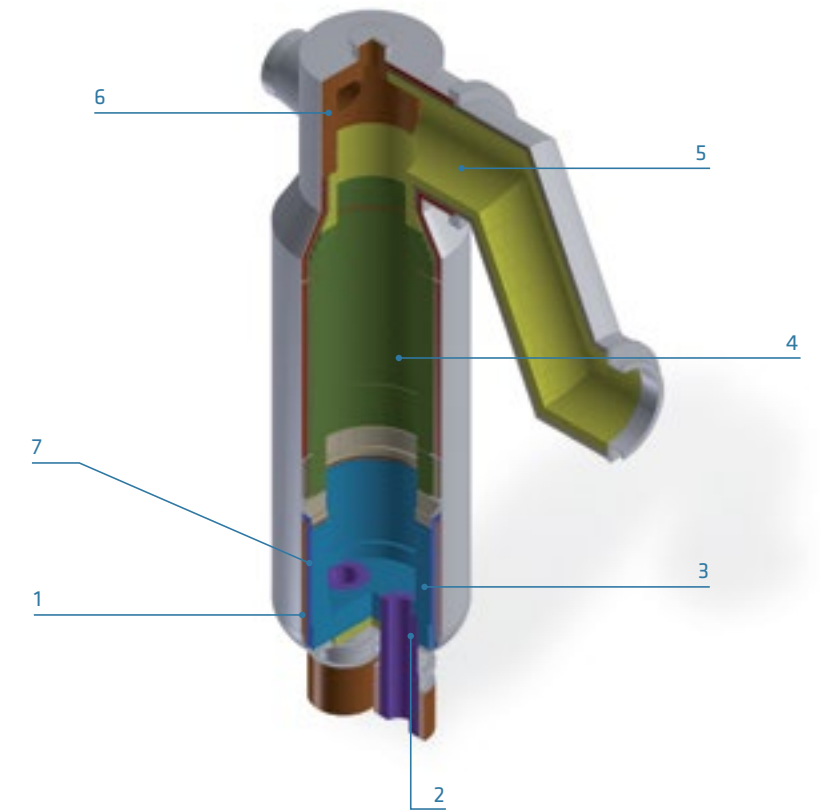
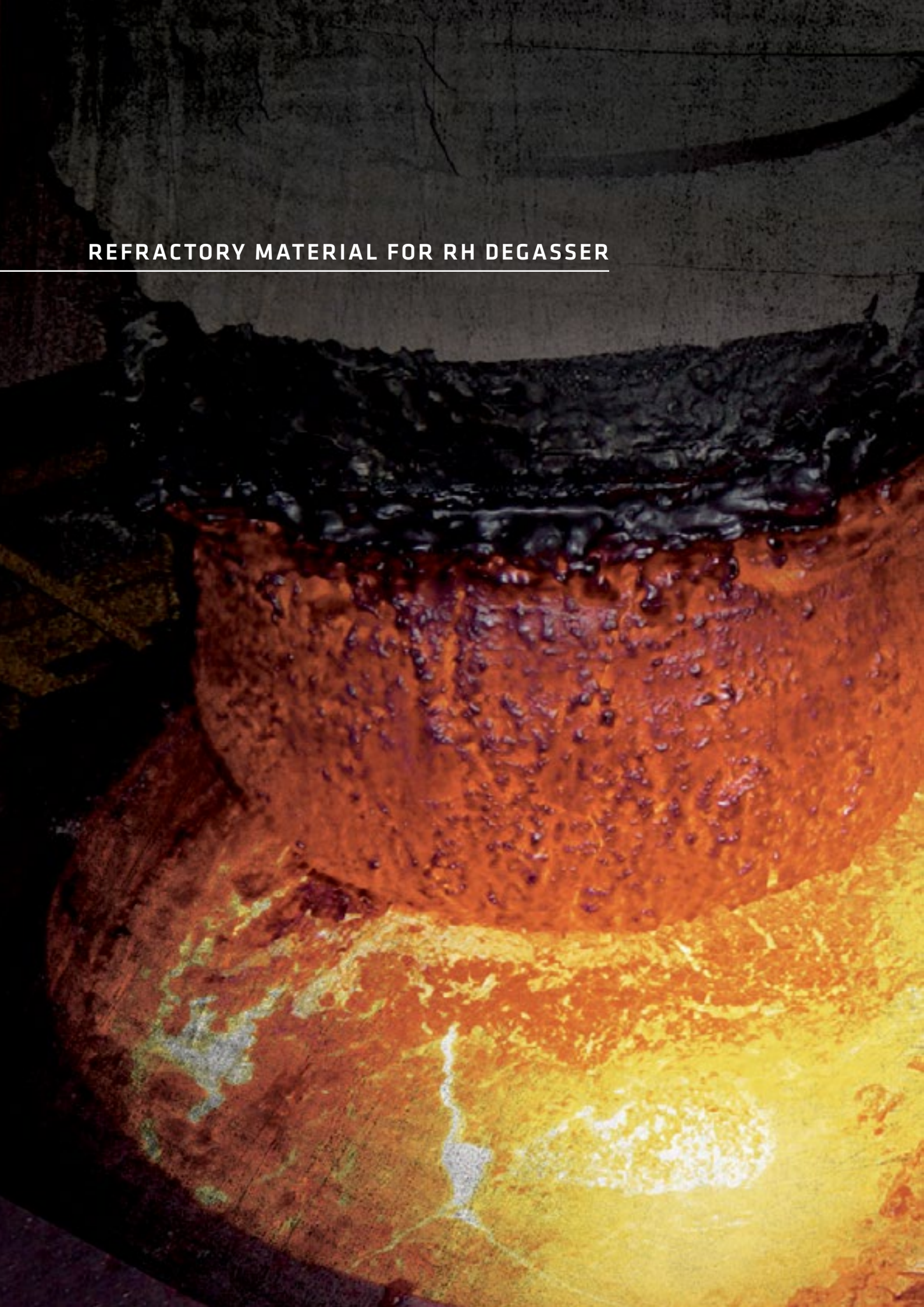

1. Insulation lining
2. Snorkel
3. Lower tank
4. Upper tank
5. Syphon
6. Dome
7. Safety lining

Working lining bricks								
Quality Name	MgO (%)	Al <sub>2</sub> O <sub>3</sub> (%)	Fe <sub>2</sub> O <sub>3</sub> (%)	Cr <sub>2</sub> O <sub>3</sub> (%)	BD (g/cm <sup>3</sup> )	AP (%)	CCS (Mpa)	Application
MFS85	86.50	9.00	-	-	3.16	7.5	110	Bricks for chamber working lining
CAST-A92TC	4.00	92.54	-	-	3.10	16.8	125	Castable for snorkels and circulator
CAST-A70CM	-	70.00	-	-	2.74	16.5	42.5	Castable for alloy chule
CR19D-RH	60.00	6.00	12.00	19.00	3.23	15	60	Bricks for lower tank
CR20D-RH	62.50	5.20	10.00	20.00	3.21	16	50	Bricks for upper tank and syphon

Safety lining bricks								
Quality Name	MgO (%)	Al <sub>2</sub> O <sub>3</sub> (%)	Fe <sub>2</sub> O <sub>3</sub> (%)	Cr <sub>2</sub> O <sub>3</sub> (%)	BD (g/cm <sup>3</sup> )	AP (%)	CCS (Mpa)	Application
CR19D	58.00	14.00	-	19.00	3.15	18	55	Safety lining
FC42	-	42.00	2.00	-	2.15	24	25	Safety lining
FC35MLW06	-	36.00	2.60	-	0.55	-	2.4	Insulation lining

Unshaped materials								
Quality Name	MgO (%)	Al <sub>2</sub> O <sub>3</sub> (%)	Fe <sub>2</sub> O <sub>3</sub> (%)	Cr <sub>2</sub> O <sub>3</sub> (%)	BD (g/cm <sup>3</sup> )	Grain Size (mm)	CCS (1600°Cx3h) (Mpa)	Application
CAST-A90C-1K	-	91.50	-	-	70	0.6	102	Castable for snorkels
CAST-A90C-2K	-	91.00	-	-	52	0-3	100	Filling for snorkels
CAST-A87CS-1S	8.50	87.20	-	-	45	0-6	82.5	Castable for snorkels
CAST-A87CS-2S	8.00	87.80	-	-	46.50	0-3	90.20	Filling for snorkels

The table does not represent all the available products. More qualities can be produced according to Customer requirements.



## REFRACTORY MATERIAL FOR TUNDISH



1. Impact pad
2. Insulation
3. Safety lining
4. Working lining

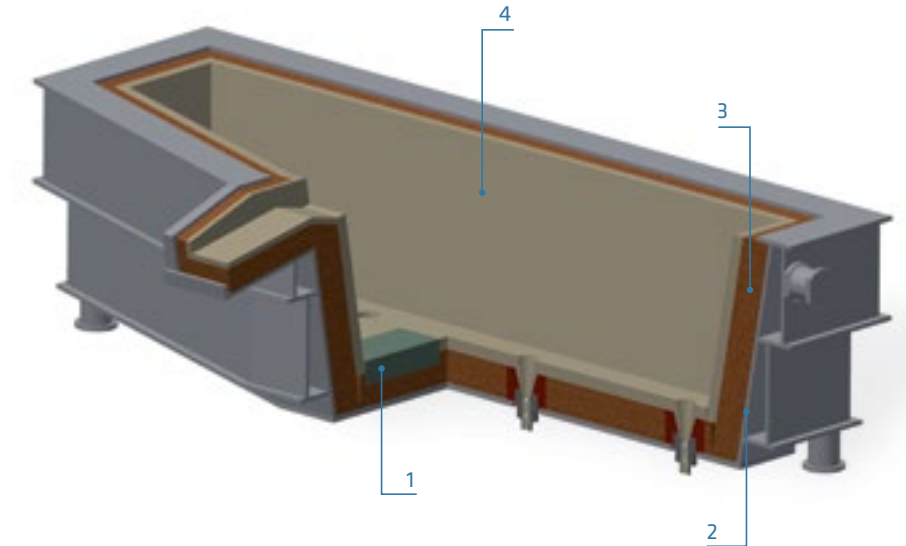

Working lining bricks									
Quality Name	MgO (%)	SiO <sub>2</sub> (%)	CaO (%)	Fe <sub>2</sub> O <sub>3</sub> (%)	Al <sub>2</sub> O <sub>3</sub> (%)	BD (g/cm <sup>3</sup> )	Grain Size (mm)	TC(1000°C) (W/mK)	Application
GUN-M67TN	67.00	20.00	1.80	4.50	2.50	1.1	0-1	0.5	Gunning material for working lining
GUN-M75TN	75.00	15.00	3.00	5.50	0.60	1.3	0-0.5	0.5	Gunning material for working lining
GUN-M85TN	85.00	5.00	9.00	0.50	0.20	1.4	0-0.5	0.5	Gunning material for working lining
DRY-M78TN	78.00	16.00	2.50	3.00	0.50	1.9	0-1	0.5	Dry setting mix
DRY-M80TN	80.00	1.30	13.00	4.50	1.20	1.9	0-1	0.5	Dry setting mix

Safety materials									
Quality Name	Al <sub>2</sub> O <sub>3</sub> (%)	SiO <sub>2</sub> (%)	CaO (%)	Fe <sub>2</sub> O <sub>3</sub> (%)	TiO <sub>2</sub> (%)	BD (g/cm <sup>3</sup> )	Grain Size (mm)	CCS (1500°Cx3h) (Mpa)	Application
CAST-A75B-TN	75.00	18.00	3.60	1.20	2.15	2.6	0-3	50	Castable for safety lining
CAST-A82B-TN	82.00	12.50	1.00	1.30	2.5	2.85	0-6	125	Low cement castable for safety lining

Insulation lining									
Quality Name	Al <sub>2</sub> O <sub>3</sub> (%)	SiO <sub>2</sub> (%)	ZrO <sub>2</sub> (%)	Fe <sub>2</sub> O <sub>3</sub> (%)	K <sub>2</sub> O+Na <sub>2</sub> O (%)	BD (g/cm <sup>3</sup> )	Max. Temperature(%)	TC(600°C) (W/mK)	Application
ALSITHERM1430-B128	34.00	50.00	15.00	0.15	0.15	0.128	1430	0.18	Insulating panel
ALSITHERM1260-B300	44.00	52.00	-	0.50	0.90	0.3	1260	0.13	Insulating panel

The table does not represent all the available products. More qualities can be produced according to Customer requirements.



## REFRACTORY MATERIAL FOR ISOSTATICS

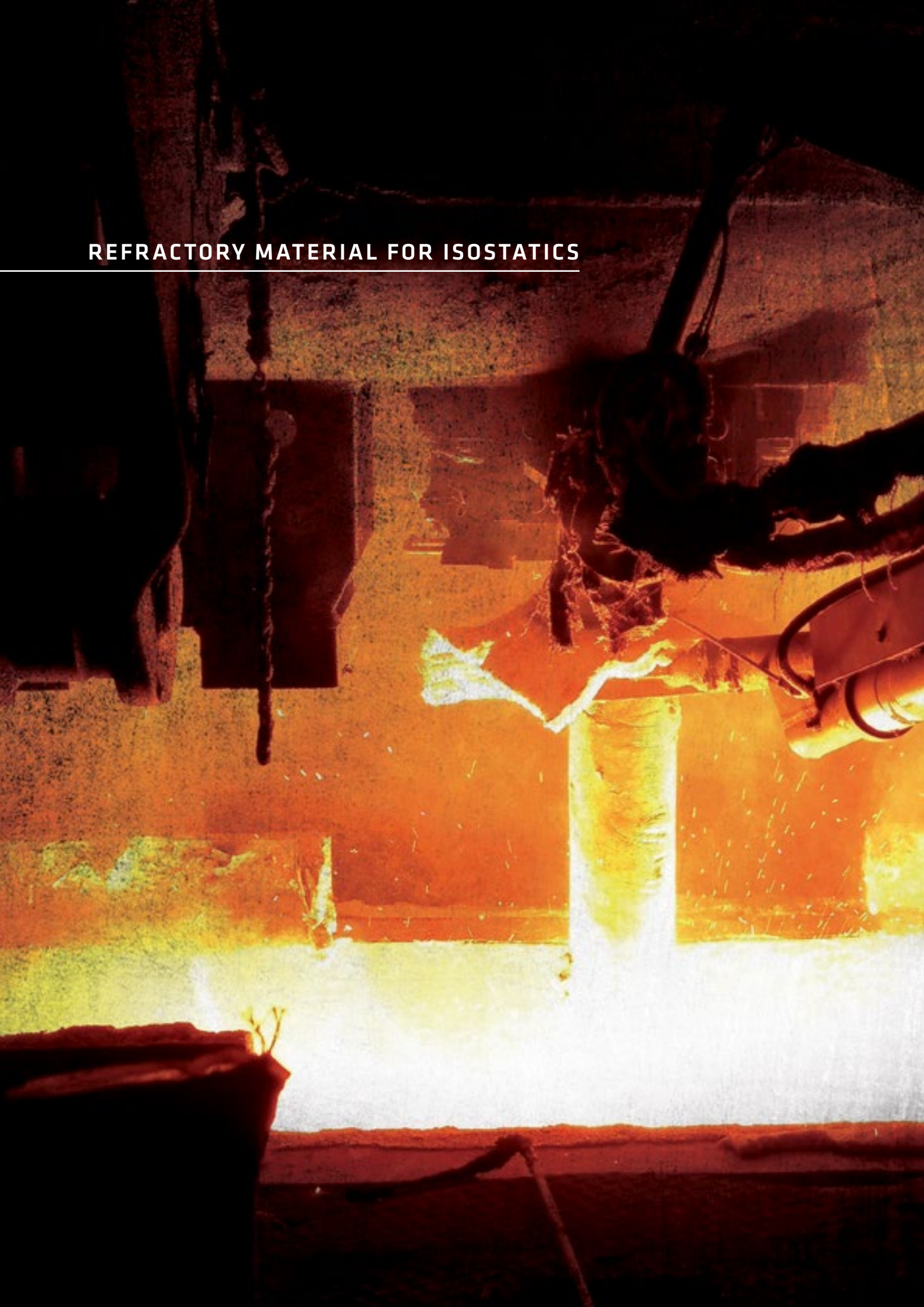

Ladle Shroud

Quality Name	Al <sub>2</sub> O <sub>3</sub> (%)	SiO <sub>2</sub> (%)	ZrO <sub>2</sub> (%)	Si+SiC(%)	Carbon(%)	BD(g/cm <sup>3</sup> )	AP(%)	CCS(Mpa)	MOR(Mpa)	Application
SHR-A50B	50.00	11.00	-	3.00	26.00	2.20	19	20	6	SHR Body / Cold start
SHR-A60B	60.00	10.00	-	3.00	20.00	2.30	15	22	7	SHR Body / Cold start
SHR-Z75SL	-	-	75.00	3.00	12.00	3.50	16	16	5	SHR Slagline
SHR-A60H	58.00	10.00	-	4.50	26.00	2.30	18	21	5	SHR Head

Submerged Entry Nozzle

Quality Name	Al <sub>2</sub> O <sub>3</sub> (%)	SiO <sub>2</sub> (%)	ZrO <sub>2</sub> (%)	Si+SiC(%)	Carbon(%)	BD(g/cm <sup>3</sup> )	AP(%)	CCS(Mpa)	MOR(Mpa)	Application
SEN-A50B	50.00	11.00	-	3.00	26.00	2.20	19	20	6	SEN Body / Cold start
SEN-A60B	60.00	12.00	-	4.50	22.00	2.40	15	20	7	SEN Body / Cold start
SEN-Z80SL	-	-	80.00	3.00	12.00	3.80	14	16	5	SEN Slagline
SEN-A80H	80.00	-	-	4.50	15.00	2.30	18	21	5	SEN Head

Monoblock Stopper

Quality Name	Al <sub>2</sub> O <sub>3</sub> (%)	SiO <sub>2</sub> (%)	ZrO <sub>2</sub> (%)	Si+SiC(%)	Carbon(%)	BD(g/cm <sup>3</sup> )	AP(%)	CCS(Mpa)	MOR(Mpa)	Application
MBS-A50B	50.00	16.00	-	3.00	29.00	2.40	18	18	4	MBS Body
MBS-A60B	60.00	11.00	-	3.00	24.00	2.65	17	21	5	MBS Body
MBS-Z65L	-	-	65.00	3.00	21.00	3.20	17	15	5	MBS Slagline
MBS-A80H	80.00	-	3.00	5.00	10.00	2.75	17	20	6	MBS Head

Tundish Nozzle

Quality Name	Al <sub>2</sub> O <sub>3</sub> (%)	SiO <sub>2</sub> (%)	ZrO <sub>2</sub> (%)	Si+SiC(%)	Carbon(%)	BD(g/cm <sup>3</sup> )	AP(%)	CCS(Mpa)	MOR(Mpa)	Application
TN-A55B	55.00	11.00	-	-	27.00	2.45	15	20	6	TN Body
TN-A65B	66.00	11.00	-	-	20.00	2.55	16	22	7	TN Body
TN-Z75SL	-	-	75.00	-	16.00	3.60	15	18	7	TN Slagline
TN-M65H	-	8.00	-	65.00	15.00	2.70	16	25	8	TN Head

The table does not represent all the available products. More qualities can be produced according to Customer requirements.



## REFRACTORY MATERIAL FOR CASTING BRICKS

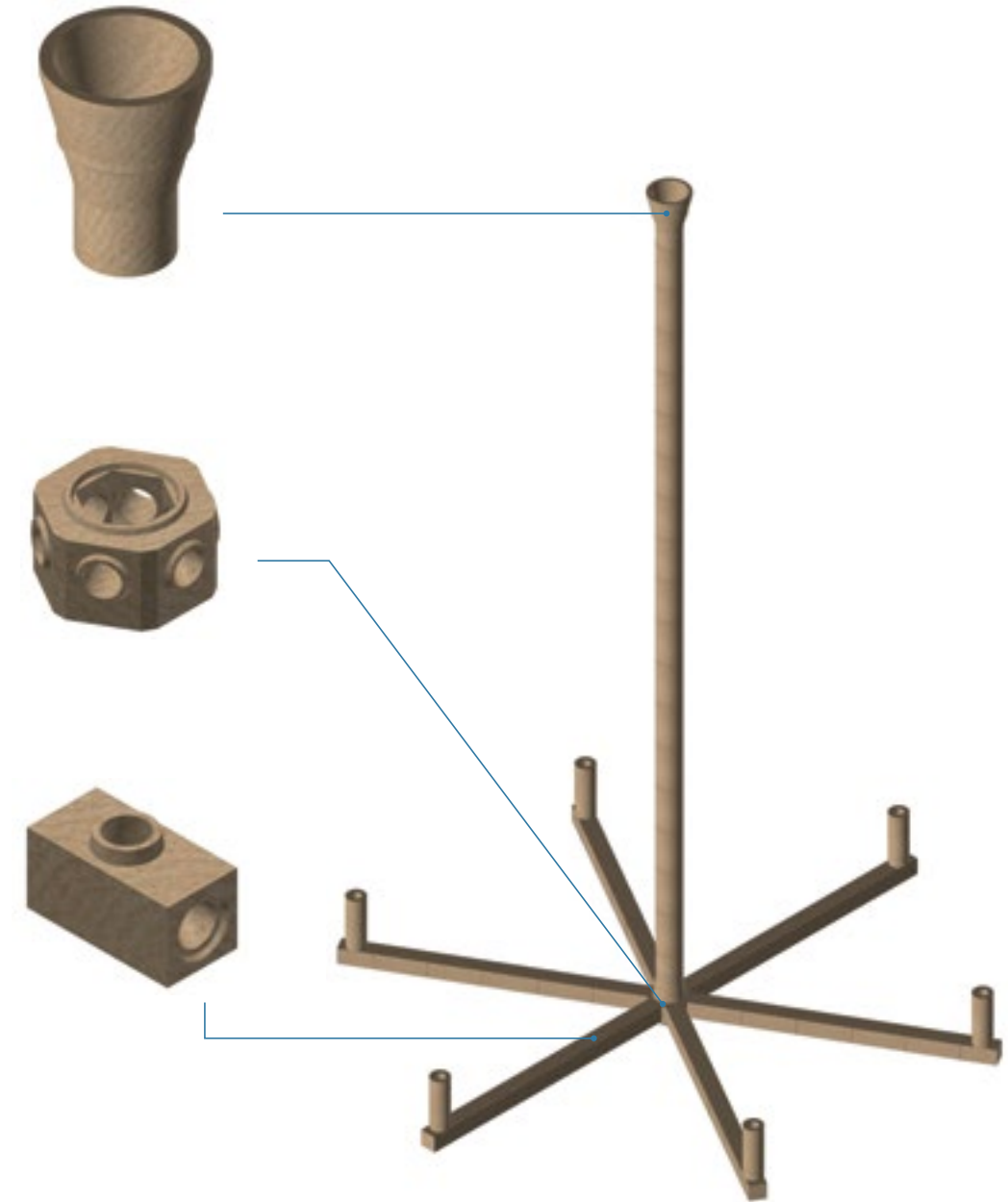
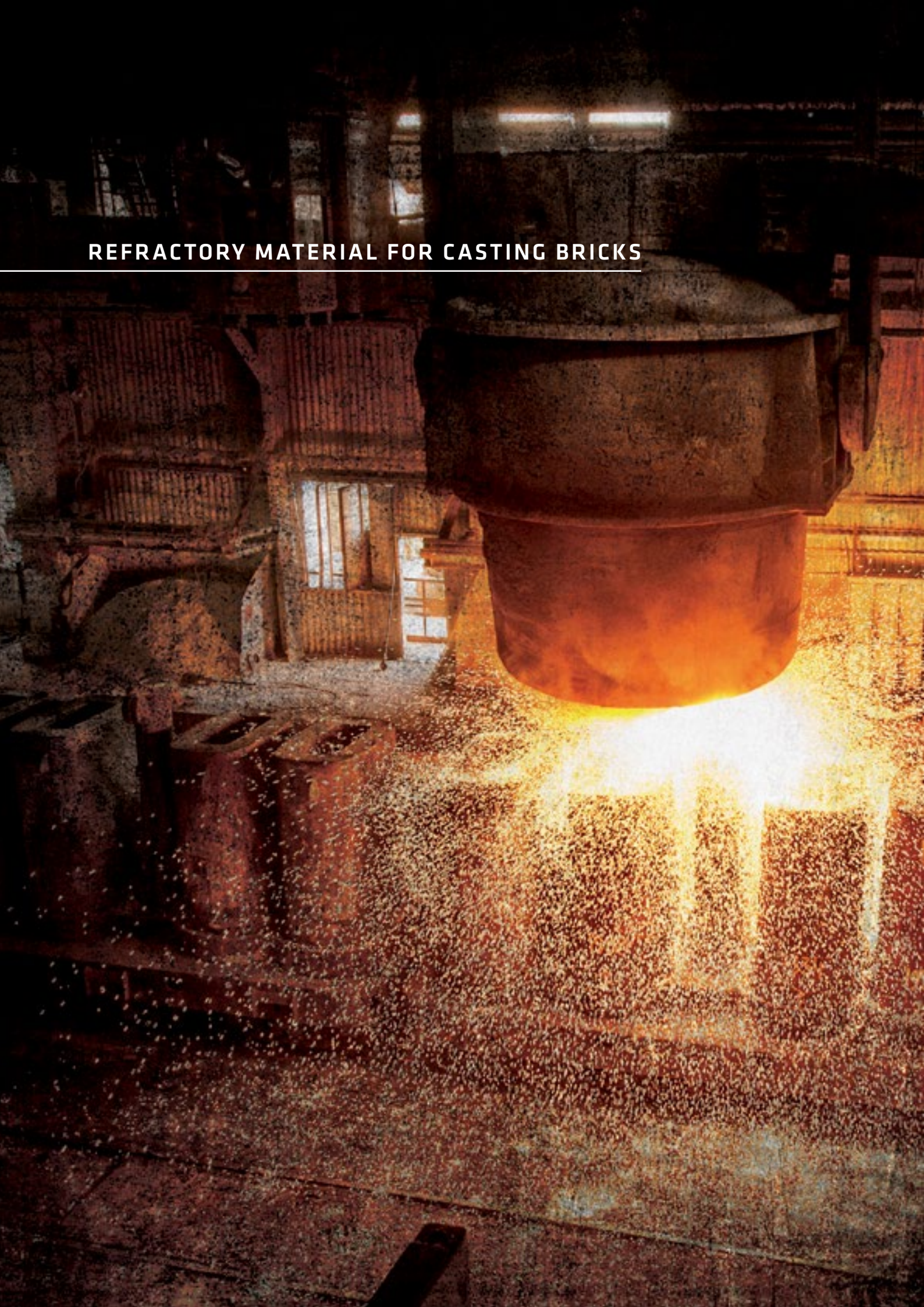

Casting Bricks								
Quality Name	Al <sub>2</sub> O <sub>3</sub> (%)	SiO <sub>2</sub> (%)	Fe <sub>2</sub> O <sub>3</sub> (%)	TiO <sub>2</sub> (%)	BD(g/cm <sup>3</sup> )	AP(%)	CCS(Mpa)	Application
HA45B-CB	45.00	51.00	2.20	2.00	2.20	26	35	Runner bricks for ingot casting
HA60B-CB	62.00	27.00	2.00	3.20	2.21	25	38	Runner bricks for ingot casting
HA65B-CB	65.00	23.00	1.80	3.00	2.25	25	40	Runner bricks for ingot casting
HA70B-CB	70.00	18.00	1.70	3.00	2.30	24	43	Runner bricks for ingot casting
HA75B-CB	75.00	20.00	1.60	3.10	2.32	24	45	Runner bricks for ingot casting

The table does not represent all the available products. More qualities can be produced according to Customer requirements.



## SPECIAL SHAPES

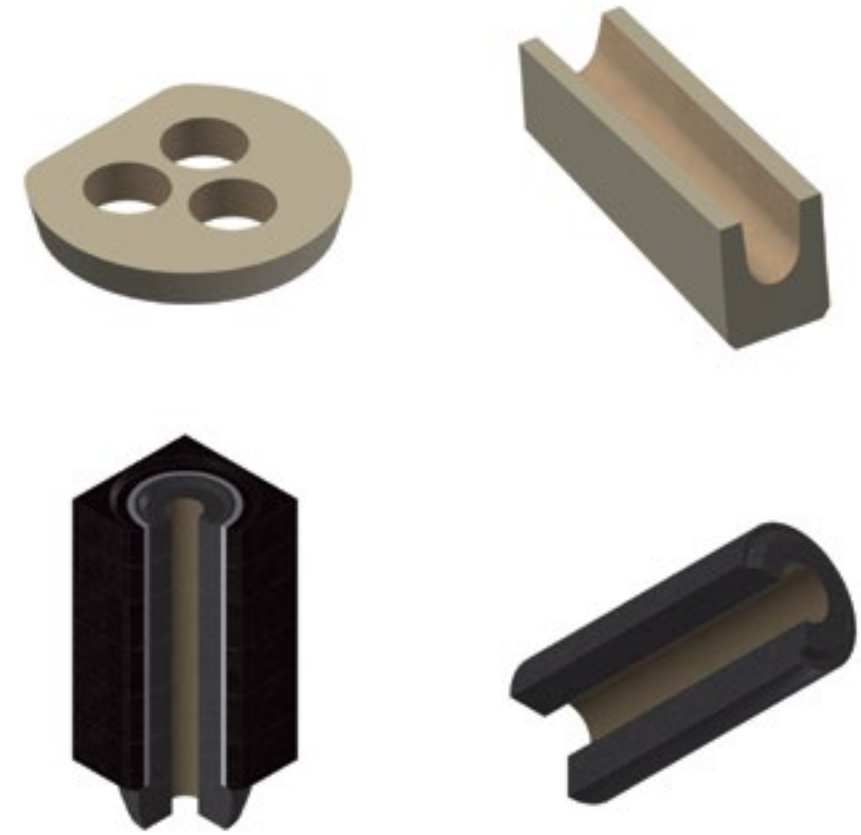

Special blocks									
Quality Name	MgO (%)	SiO <sub>2</sub> (%)	CaO (%)	Fe <sub>2</sub> O <sub>3</sub> (%)	Carbon (%)	BD (g/cm <sup>3</sup> )	AP (%)	CCS (Mpa)	Application
A15C7-SR	98.06	0.43	0.89	0.41	15.00	2.98	4	40	EAF EBT
E15C7-SR	97.80	0.38	0.97	0.58	15.40	2.97	5	30	EAF EBT
A15C7T	98.13	0.40	0.92	0.40	15.00	2.99	4	40	Converter tap hole
EA14RT	98.20	0.40	0.98	0.42	14.00	2.96	4	40	Converter tap hole

Roof									
Quality Name	MgO (%)	Al <sub>2</sub> O <sub>3</sub> (%)	CaO (%)	Fe <sub>2</sub> O <sub>3</sub> (%)	Cr <sub>2</sub> O <sub>3</sub> (%)	BD (g/cm <sup>3</sup> )	Grain Size (mm)	CCS (1600°Cx3h) (Mpa)	Application
CAST-A90CSDLT	6.00	90.00	0.80	0.05	-	3.1	0-8	95	EAF spout
CAST-A90CCR	-	90.00	-	0.50	2.30	3.15	0-6	100	EAF and LF roof precast block

Unshaped materials									
Quality Name	MgO (%)	SiO <sub>2</sub> (%)	CaO (%)	Fe <sub>2</sub> O <sub>3</sub> (%)	Cr <sub>2</sub> O <sub>3</sub> (%)	Al <sub>2</sub> O <sub>3</sub> (%)	BD (g/cm <sup>3</sup> )	Grain Size (mm)	Application
THF-M470	47.00	44.00	0.60	8.00	2.00	-	-	2-6	EBT and tap hole olivine
RAM-M94V	93.50	1.00	1.80	1.20	0.80	0.3	2.2	0-5	EBT filling

The table does not represent all the available products. More qualities can be produced according to Customer requirements.



## SLIDING GATE SYSTEM MECHANICAL

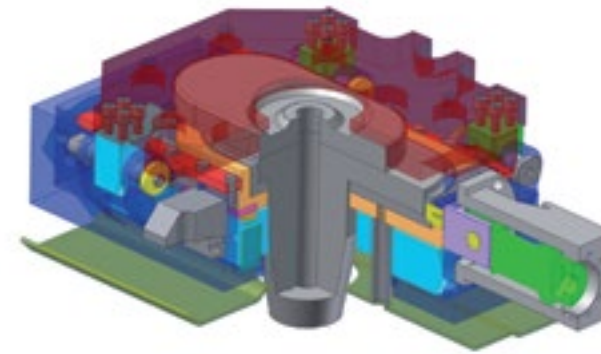

The Sliding Gate System TRS-1000L provides multiple advantages for an easier use and higher performance:

- **Simplicity:** reduction of components, quicker application on the ladle, Interchangeability with existing systems, reduction of maintenance
- **Dimensions:** the reduced dimensions of TRS1000L guarantee the application of the system without the need of changes to the standard settings
- **Speed:** quicker change of refractories, closing with hydraulic system, reduction of ladle preparation time
- **Performance:** high performance of the refractories guaranteed by high quality of products and reliability of the system, holding between refractory plates ensured by a system of heat-resistant springs and by a stroke of 150 mm

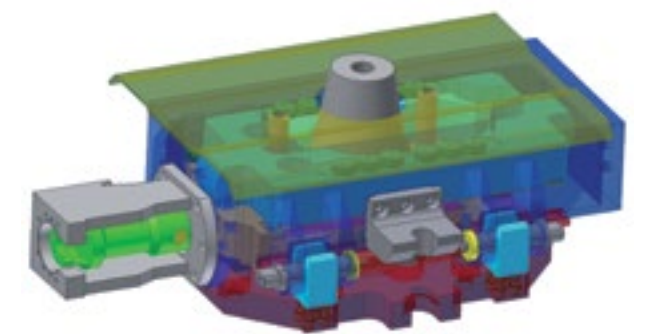

Slide gate system						
Model	Casting bore diameter(mm)	Length(mm)	Width(mm)	Thickness(mm)	Stroke(mm)	Ladle capacity(MT)
TRS-1000L	35 - 60	715	520	256 (without tip) 346 (including tip)	150	30 - 150

The table does not represent all the available products. More qualities can be produced according to Customer requirements.



## SLIDING GATE SYSTEM REFRACTORY

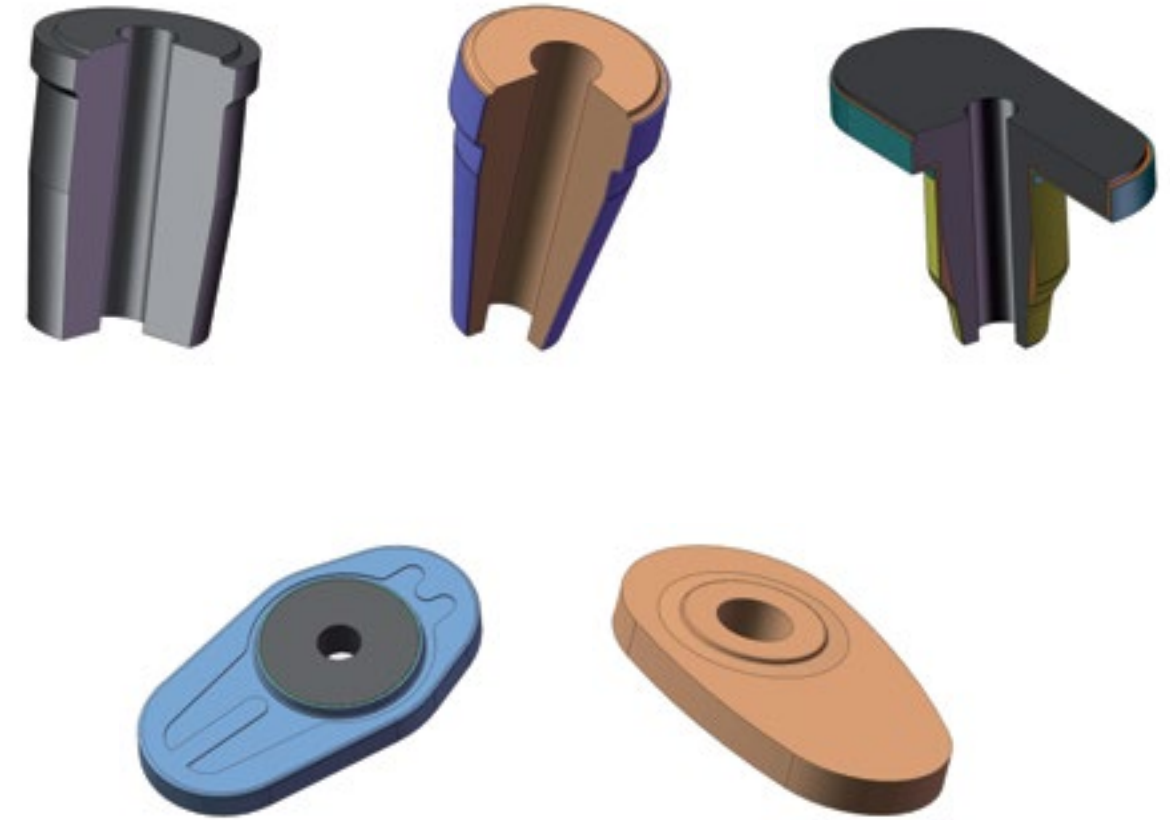

Slide gate plates								
Quality Name	Al <sub>2</sub> O <sub>3</sub> (%)	MgO(%)	ZrO <sub>2</sub> (%)	Carbon(%)	BD(g/cm <sup>3</sup> )	AP(%)	CCS(Mpa)	Application
SP-A70BU	72.00	-	-	6.00	2.85	8	70	Alumina Carbon unfired plate
SP-A85BU	86.00	-	-	3.00	3.10	10	100	Alumina Carbon unfired plate
SP-A75ZF	75.00	-	6.50	7.00	3.05	7	115	Alumina Zirconia Carbon fired plate
SP-A80CF	80.00	-	-	5.00	3.00	9	93	Alumina Carbon fired plate
SP-M80AF	12.00	80.00	-	2.50	2.97	10	85	Magnesia Fired Plate

Nozzles								
Quality Name	Al <sub>2</sub> O <sub>3</sub> (%)	MgO(%)	ZrO <sub>2</sub> (%)	Carbon(%)	BD(g/cm <sup>3</sup> )	AP(%)	CCS(Mpa)	Application
IN-A80	80.00	-	-	4.00	3.00	13	65	Inner Nozzle
IN-A90	90.00	-	-	4.00	3.00	12	100	Inner Nozzle
CN-A80	80.00	-	-	5.00	3.00	15	75	Collector Nozzle
CN-A90	90.00	-	-	3.00	3.00	13	90	Collector Nozzle

The table does not represent all the available products. More qualities can be produced according to Customer requirements.





## TECHNICAL ASSISTANCE AND OPTIMIZATION OF REFRACTORIES APPLICATIONS

Trasteel prouls itself on the quality of its engineering staff, which is capable of optimizing the performance of its materials even in extreme working conditions.

Besides, it can offer a wide range of services, teaming up with customer's technical staff and reducing the transformation costs of the mill.

Trasteel technical team provides complete assistance and consulting in order to maximize the results of its products. Its services go beyond a simple product-related service, as listed below:

- Study, design and optimization of all refractories lining by using thermal calculation and dynamic model
- On-site training to steel plant technicians on the refractory operation
- Development of 4.0 Industry, by providing software and tools in order to monitor the refractories life with forecast analysis and therefore bettering the stock management
- Detailed practical and theoretical studies related to the electric arc furnaces and their operations
- Monitoring and optimization of operational, mechanical and electrical variables which affect the performances of the electric arc furnaces
- Monitoring and optimization of operational and mechanical performance of the refractory
- Calculation of productivity increase
- Furnace start-up assistance
- Furnace Regulation
- Hydraulics
- Evaluation of power supply system
- Evaluation of transformer performance
- Evaluation of load current and current balance between phases
- Optimization of melting efficiency
- Optimization of graphite electrodes consumption
- Customized Reporting
- Interaction with customer's data - PLC
- Inspection of accessories







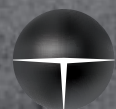

**TRASTEEL**  
refractory solutions

**Trasteel International SA**

Via F. Pelli, 12 | 6900 Lugano | Switzerland

T +41 (0)91 910 5300 | F +41 (0)91 910 5353

[www.trasteel.com](http://www.trasteel.com)